



ELSEVIER

Forest Ecology and Management 91 (1997) 83–91

Forest Ecology  
and  
Management

# ‘Without bamboo, the land dies’: A conceptual model of the biogeochemical role of bamboo in an Indonesian agroforestry system<sup>1</sup>

L. Christanty<sup>a</sup>, J.P. Kimmins<sup>b</sup>, D. Maily<sup>b,\*</sup>

<sup>a</sup> *Gelong Baru Barat VI / 8, Tomang, Jakarta 11440, Indonesia*

<sup>b</sup> *Faculty of Forestry, Department of Forest Sciences, University of British Columbia, Vancouver, BC V6T 1Z4, Canada*

## Abstract

The ‘talun-kebun’ system consists of a 6–7 year management cycle in which a 4–5 year fallow period of perennial clump bamboo is alternated with 2 years of food crop production. Clearcutting, raking the forest floor and slash into piles for burning, and hoeing the soil to a depth of 25 cm reduces the vigour of the bamboo to the point at which it poses no competitive threat to the first year of planted food crops. These crops are (typically) cucumber, bitter solanum and hyacinth (pole) beans. Ash from the burned slash piles, plus some animal manure and application of NPK fertiliser (only recently), are used to increase the production of these vegetables. In spite of these nutrient additions, the fertility of the upper soil layers declines during the first year, and the field is planted to cassava (a less nutrient-demanding root crop) the second year after clearcutting. After 2 years of cultivation, bamboo regrowth and declining soil fertility prevent continued food cropping. The field is abandoned and permitted to revert to an unmanaged stand of bamboo for 4–5 years. The historical success of the system appears to be based largely on the ‘nutrient pumping’ action of the bamboo, the slow decomposition of its silica-rich litter, and the extremely high biomass of bamboo fine roots. Studies reported earlier and in subsequent papers support the interpretation that the bamboo recovers much of the nutrients leached deeper into the soil profile during the 2 years of cropping and deposits them at or near the soil surface as above-ground litter and dead fine roots. The biogeochemical role of bamboo in sustaining the productivity of this agroforestry system reflects the rural farmer’s saying: ‘without bamboo, the land dies’.

*Keywords:* Shifting cultivation; Talun-kebun; Biogeochemistry; Java

## 1. Introduction

It is generally agreed that the main causes of deforestation in tropical areas are population resettlement schemes, forest clearance for large-scale agriculture, forestry enterprises and animal production, and, in particular, shifting cultivation (Nair, 1993). The conversion from forest to food production has

\* Corresponding author. Tel.: 1 (604) 822-6018; fax: 1 (604) 822-5744; e-mail: maily@unixg.ubc.ca.

<sup>1</sup> Paper submitted for publication during the International Symposium on Agroforestry and Land Use Change in Industrialised Nations, Berlin, 29 May–2 June 1994.

frequently resulted in land degradation, and there is growing interest in the use of integrated land management systems which combine agriculture and forestry to reduce this environmental deterioration (Bene et al., 1977). This combined system, known as agroforestry, is a promising solution to the conflict between food and wood production in tropical countries (Satjapradja, 1982).

Use of the term agroforestry is relatively recent, but the practice of combining tree and food crops has existed for many centuries. It has been the traditional land use method of rural people in most tropical countries (Nair, 1993), and although such traditional crop production systems can have some short-term adverse environmental impacts, they have generally been practiced on a crop cycle of sufficient length to sustain production over at least several centuries (Christanty et al., 1986).

Much can be learned by both foresters and agriculturalists from the study of traditional agroforestry, and the knowledge thus gained can be used as the basis on which to develop improved cropping methods. Because they are traditional, agroforestry systems, or modern variants thereof, have had a high level of social acceptance, and local farmers have been prepared to use them (Christanty, 1989). In many parts of the tropics, agroforestry systems are potentially much more suitable than various alternative agricultural methods, which often experience problems of pests, diseases, soil erosion and soil impoverishment. Thus, from both a social and a biophysical point of view, there is much less risk in developing modern agroforestry based on traditional agroforestry methods for use in tropical environments than in introducing completely new agricultural strategies that are unproven for the local conditions (Marten, 1986). The successful development of the 'taungya' system in Burma from shifting cultivation (Grandstaff, 1980) is a good example. However, improving the productivity of agroforestry requires a clear understanding of how traditional agroforestry systems function and of the extent to which they can be altered/modified without the risk of unacceptable damage to the site.

The objectives of this paper are to describe the bamboo 'talun-kebun' system of West Java (Indonesia), and to present a conceptual model of the biogeochemical basis for the historical, sustained

success of this well adapted traditional agroforestry system.

## **2. Description of the bamboo talun-kebun**

Because of the high and growing population density in many areas of Java, most farmers are forced to obtain their subsistence from a very limited and diminishing area of land. Consequently, these farmers have had to develop food production methods that have a higher productivity and a greater sustainability of production than traditional shifting cultivation methods. Talun-kebun is one of the systems that has been developed from low productivity, conventional shifting cultivation methods (Soemarwoto et al., 1985; Palte, 1988). It requires much less land, has a shorter rotation cycle, and has been practiced on poor sites. A traditional version of this system (described below) has been widely practiced for six generations by upland farmers in West Java, Indonesia, but with increasing population pressure and aspirations of a higher standard of living, the traditional practices are now being changed. In order to identify the extent to which this environmentally stable system can be modified without causing site degradation and loss of production, a thorough understanding is needed of the major ecological processes that have rendered the system sustainable.

The talun-kebun is defined as an upland land use system in which annual food or cash crops are alternated sequentially with tree crops. Its overall pattern is similar to that of traditional shifting cultivation, but the length of the fallow period is much shorter and there is a deliberate selection of the species used in each stage. Talun-kebun consists of two basic stages: the 'talun' (perennial crop garden) and the 'kebun' (annual crop garden). The talun stage is comparable to the forest fallow period of shifting cultivation, during which the field is dominated by a mixture of perennial species. Based on its dominant species, talun in West Java is divided into three types: woodlot (dominated by a mixture of fuelwood and timber species); permanent mixed talun (dominated by a mixture of fruit trees and perennial cash crops); and bamboo talun (dominated by bamboo species with scattered trees between bamboo clumps).

The bamboo talun constitutes the best example of a talun-kebun rotation cycle. Since most of the marketable production in a permanent mixed talun is derived from fruit, tree cutting is rarely done and therefore there is no clear rotation cycle between talun and kebun. Clearcutting is practiced in the woodlot only if the trees are homogenous in age. Otherwise, selective cutting is employed as the main harvest method, and therefore the talun-kebun cycle is again not represented. In contrast, harvesting in a bamboo talun is usually done by clearcutting, which leaves the rhizomes alive but reduced in vigour. After clearcutting, the field is cultivated in preparation for a period of food crop production: the kebun stage. Cropping is usually abandoned after two years because of competition from the bamboo regrowth, weed invasion, and because of the experience that productivity declines due to lowered soil fertility if food cropping is continued. The field is allowed to revert to the talun stage for 4–5 years, after which the soil fertility has been restored and the field is ready for the next clearing and cropping. A complete rotation cycle takes about 6–7 years, depending on the type of plant species grown.

The development of the bamboo talun-kebun probably occurred in response to soil and forest deterioration following a progressive shortening of the fallow period. Bamboo was able to invade and increase in abundance in these degraded forests. Farmers learned through experience that such bamboo-wooded forests could be managed on relatively short cycles for both food and wood products. As the increasing pressures of continued population growth cause a shortening of the bamboo fallow period, the challenge will be to design management strategies that sustain ecosystem integrity (Kimmins, 1995) and productivity of these mountain forest management systems.

The bamboo talun-kebun of West Java is dominated by various species, among which *Gigantochloa ater*, *Gigantochloa verticillata*, *Gigantochloa apus*, and *Bambusa vulgaris* are the common bamboo species. *Albizia falcataria*, *Parkia speciosa*, *Arenga pinnata* (sugar palm) and some fruit trees (mango, durian) are found scattered between the bamboo clumps. The mixture of perennial trees and bamboo forms a multilayered canopy structure. The uppermost canopy layer is usually occupied

by *Albizia*, *Parkia* and *Arenga*. Mango and other fruit trees dominate a second layer, while the lowest layer is occupied by bamboo. Since bamboo has a very dense canopy structure, there is practically no undergrowth in a mature bamboo talun; however, scattered native understory species are sometimes found in the open spaces between clumps, where sunlight is still able to penetrate.

Hyacinth bean (*Dolichos lablab*) is the main crop planted during the first year of the kebun stage. It is usually intercropped with cucumber and black nightshade (bitter solanum; *Solanum nigrum*). Crops are usually grown in rows along contour lines, with different species planted in alternate rows. Other crops commonly planted in the kebun are: sweet basil (*Ocimum basilicum*), bitter melon (*Momordica charantea*), and chili pepper (*Capsicum frutescens*). Maize (*Zea mays*) and cassava (*Manihot esculenta*) are frequently planted along the edges of the kebun.

The lowest layer of canopy stratification during this first year of the kebun stage is occupied by cucumbers, which creep along the ground, suppressing the growth of non-crop plant species. Various vegetables (e.g. bitter solanum, chili pepper and sweet basil) occupy the middle layer, while the upper layer is occupied by hyacinth beans which grow up bamboo poles, mixed with fruit trees, young *Albizia*, and other trees which were left uncut during the clearing of the bamboo. Growth of non-crop plant species during the first cropping period is minimised by manual weeding before the mature bamboo talun is cut, and regular manual weeding before the harvest period of each food crop species. By the end of the first year of cropping, weeds have invaded and occupied most of the area. These are killed during soil hoeing before planting of the second year crop.

The second year of the kebun stage is characterised by row cropping of cassava mixed with young bamboo regrowth and some scattered trees. Three canopy layers are formed: a scattered upper layer occupied trees, followed by the initially small but expanding clumps of young bamboo in the middle layer and cassava in the lowest layer. These three canopy layers are spatially separated, the bamboo being limited to the area between the trees, with the cassava between bamboo clumps and the trees. No weeding is done, and consequently weeds quickly occupy the spaces between the cassava rows and

become abundant by the end of the cropping period. After harvesting the cassava (about two years after the bamboo was clearcut), there is no further cultivation of the field, permitting the bamboo to regrow until it is ready for the next harvest. Weeds are gradually shaded out as the bamboo dominates the

site, and are almost completely eliminated from the site by the mature stage of the bamboo talun.

The sequence of cultural activities begins with preparation for planting of food crops. This preparation, which includes litter raking, piling and burning, and soil hoeing takes place in the mature bamboo

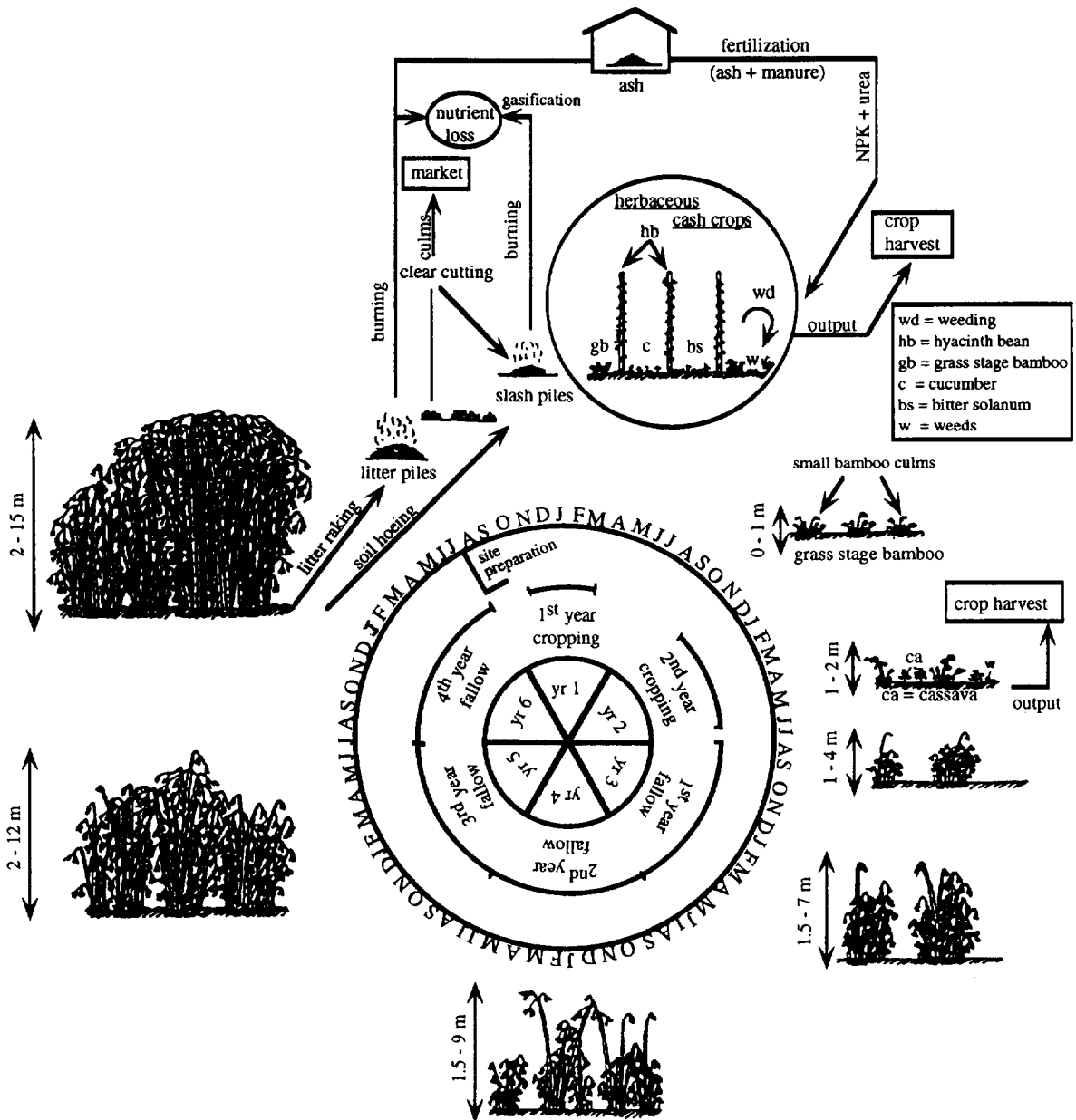

Fig. 1. Diagrammatic summary of the bamboo talun-kebun cropping cycle in Soreang, West Java, Indonesia.

stage before the bamboo is cut (the work is more pleasant in the cool shade of the bamboo). The mature bamboo culms and mature *Albizia* are often clearcut, but the young bamboo culms (i.e. the most recently grown culms which are still soft and have a high moisture content) are not cut until they have become dry by exposure to the sun. Harvest residue (leaves and small branches) from the clearing is piled and burned after drying in the sun. Ash from the burning of both litter and harvest residue is collected and placed in a small hut, to be mixed with livestock manure and used for fertiliser during cropping.

The mature bamboo culms and the stems of *Albizia* are removed from the field for sale (mostly as building materials). When they have dried, the young culms are cut and set up in rows (with a defined spacing within and between rows) for use as supporting poles for hyacinth beans. Planting holes for bean seeds are prepared at the base of the bamboo poles, and shallow furrows are made between the rows for cucumber and bitter solanum. These preparations for planting take about two to three months (depending on the size of the clearing and the availability of labourers) at the end of the dry season (August–October).

The first year cropping sequence starts with the planting of hyacinth bean seeds after the first rain (end of October/early November). Three seeds are planted in each hole (two holes and six seeds per pole), and the hole is covered with a mixture of ash and manure. Cucumber seeds are planted in the furrows a week after planting the hyacinth bean and also fertilised with ash and manure. Seedlings of bitter solanum are transplanted from a nursery area three weeks after planting the cucumber. The second fertilisation, which consists of commercial NPK fertiliser mixed with ash and manure, is applied 2 or 3 weeks after planting. The hyacinth bean receives an additional fertilisation with urea after another 6 weeks. Weeding is done regularly (once or twice a month) before each harvest, and the weeds are composted in the field. The first product to be harvested is cucumber, about 40 days after planting. Cucumber harvest continues every 3–5 days for up to 2 months. Bitter solanum can be harvested weekly, starting about 1 month after it has been established, for a period of 3–4 months. Hyacinth bean is harvested

after the bean plants have senesced and the pods have dried, about 6 or 7 months after planting. Harvest of the hyacinth beans ends the first year cropping sequence. The field is rested for 2 or 3 months until the dry season ends and the soil is then hoed to remove weeds and to prepare the field for the second year of cropping.

The main crop grown in the second year is cassava. This species does not require intensive maintenance, and fertilisation and weeding are rarely done. The cassava is ready for harvest after 8 or 9 months, depending on the variety planted. The second year cropping ends after the cassava harvest.

The bamboo clumps start to sprout 'grass stage' shoots (less than 50 cm tall, slender leafy shoots) from the underground rhizomes during the first year of cropping, and small culms (larger, woody-stemmed shoots with leaves borne on branches) are produced during the second year. At the end of the second year, the shade cast by the bamboo and other perennials limits the further growth of food crops, and the field is permitted to revert to the talun stage, which will be ready for the next clearcut harvest after 4 or 5 years (sometimes 6) of bamboo fallow. Farmers often use the colour of the upper mineral soil as a guide as to the timing of the next cropping: if the colour of the mineral soil below the litter layer is black or dark, farmers consider that the field is ready for the next period of cropping. The complete sequence of a bamboo talun-kebun is shown in Fig. 1.

### 3. The conceptual model

The overall biogeochemical characteristics of the bamboo talun-kebun system are represented in Figs. 2 and 3 in the form of flowcharts which summarise the four different stages of the bamboo talun-kebun: the bamboo talun (Fig. 2(a)), the clearing of bamboo and burning (Fig. 2(b)), first year cropping (Fig. 3(a)), and second year cropping (Fig. 3(b)). These four stages make up a complete rotation cycle of a bamboo talun-kebun. The system is shown as a series of major compartments (large boxes), minor compartments (small boxes), transfer pathways (lines and diamonds joining boxes) and inputs/outputs (circles). The compartments represent biomass and

nutrients. The transfer pathways and the inputs/outputs may represent both biomass and nutrients or just nutrients. The following description of the biogeochemistry of the talun-kebun represents an hypothesis. The field data that have been collected to test this hypothesis (Christanty, 1989) will be presented in subsequent papers.

There are three major compartments within the system: vegetation, litter layer and mineral soil. Nutrients are transferred or exchanged between compartments by various processes, such as foliar leaching, litterfall, and nutrient uptake. Inputs of nutrients to the system occur in the form of precipitation, biological nitrogen fixation, upslope runoff or erosion, and soil weathering. Nutrients are removed from the system (outputs) through vegetation harvesting, downslope runoff or erosion, and soil leaching. Fertilisation is an additional input during the first year of the cropping stage (Fig. 3(a)).

The diagram for the bamboo talun stage repre-

sents processes that are operating during the recovery (fallow) phase of bamboo growth as well as during the mature bamboo stage (Fig. 2(a)). Nutrients in vegetation are returned to the soil surface through litter fall and foliar leaching, and the decomposition of litter results in the release of nutrients for uptake by plants (Sanchez, 1976; Norman, 1979). Because of the relatively slow decomposition of bamboo leaf and sheath litter, litterfall exceeds decomposition and therefore a litter layer accumulates. A mat of fine roots (less than 2 mm in diameter) and small roots (2–5 mm) develops within this organic layer and at the mineral soil surface, and it has been demonstrated (Stark and Jordan, 1978) that such root mats act as an efficient nutrient recovery mechanism which minimises leaching losses to the subsoil in tropical forest. Bamboo roots are also distributed to a depth of about 75 cm in the mineral soil. Uptake of nutrients from these deeper layers of soil is thought to constitute a 'nutrient pump' which recovers nutri-

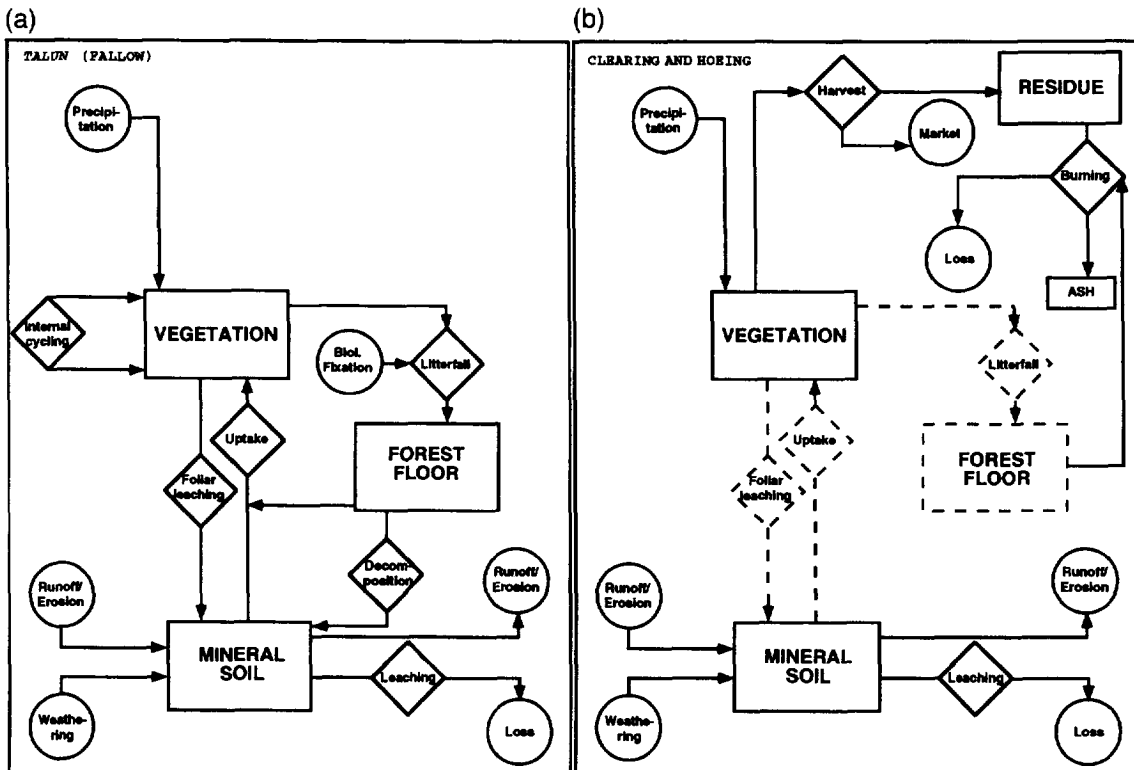

Fig. 2. Flowchart summary of the biogeochemistry of (a) the fallow stage (talun) and (b) the clearing and hoeing stage of the bamboo talun-kebun system, in Soreang, West Java, Indonesia. The number and importance of transfer processes and compartments represented vary at different stages.

ents from lower in the soil horizon and deposits them in the accumulating litter layer, thereby helping to maintain the long-term productivity of the system (Christanty, 1989). Nutrient losses during this stage may occur through runoff, erosion and/or soil leaching, but they are thought to be balanced by gains from precipitation, biological fixation, upslope runoff/erosion and soil weathering.

Disturbance of the 'tight' biogeochemical cycle of these bamboo stands occurs during the clearing of bamboo and the burning of litter and harvest residue (Fig. 2(b)). Most of the nutrient losses from the system at this stage are believed to be due to the removal through harvest export, litter raking and burning, with smaller losses due to soil leaching. Approximately  $19 \text{ Mg ha}^{-1}$  of fine and small roots are killed by hoeing, resulting in a transfer of organic matter from live bamboo biomass to soil organic matter, and a major reduction in bamboo vigour (Christanty, 1989). Because of the removal of har-

vested material and burning of litter and slash, outputs from the system at this stage are far greater than inputs. The availability of soil nutrients, however, is increased considerably following clearing and burning, and the reduction in the 'tightness' of the biogeochemical cycle is compensated by higher inputs to the system during the subsequent cropping stage: fertilisation and biological nitrogen fixation, mostly by *Albizia*, but also by hyacinth beans.

In conventional shifting cultivation, farmers commonly plant the most nutrient demanding crops in the first year of cropping, presumably to take advantage of the increased nutrient availability (Sanchez, 1976; Jordan, 1985). In the kebun stage of the bamboo talun-kebum, the first-year vegetable crops include nitrogen fixing legumes, reflecting the farmers concern over maintenance of the productivity of the site. This stage is characterised by relatively high inputs (fertiliser and ash/compost) and intensive crop maintenance (e.g. weeding). As the growth of

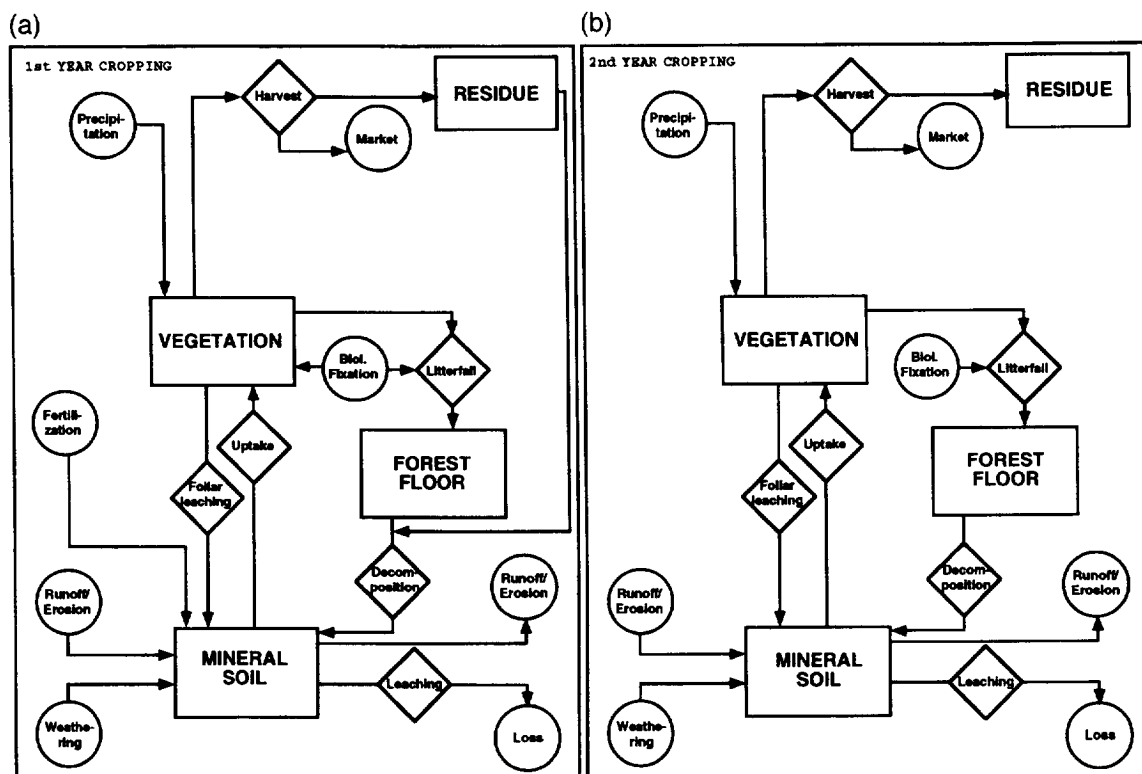

Fig. 3. Flowchart summary of the biogeochemistry of (a) first-year cropping, and (b) second-year cropping of the bamboo talun-kebum system, in Soreang, West Java, Indonesia. The number and importance of transfer processes and compartments represented vary at different stages.

perennials (bamboo and other trees) has not yet fully recovered from the disturbance of clearcutting, and as most of roots of the annual crop plants only occupy the upper part of the soil, uptake from lower in the soil profile is less than in the mature talun stage.

As in traditional shifting cultivation, cassava (a much less nutrient demanding species) is chosen as the second year crop of the kebun stage. No fertiliser is applied and cassava is frequently left without further maintenance. Consequently, weed invasion becomes a problem by the end of the cropping period, leaving farmers with no choice except to abandon the field until the bamboo and other perennials become mature and ready for the next harvest. Without any further disturbance, the biogeochemical cycle during the recovery stage gradually approaches that of the mature bamboo stage.

Considering the fact that the bamboo talun-kebum rotation cycle has sustained itself for at least six generations with minimum external inputs of nutrients (the use of NPK fertilisers and urea is relatively recent), the traditional fallow period which has been used by the local farmers may be the minimum period needed for the recovery of soil fertility, although it also involves other considerations such as the optimum size of bamboo for sale as construction material. The recent trend toward a shortening of the fallow period raises questions as to how much shorter the fallow period could be and yet still sustain the production of food crops, what other species could be used as alternatives to bamboo and *Albizia*, and what are the implications of such changes for fertiliser and pesticide requirements?

#### 4. Discussion

The importance of bamboo in maintaining the fertility and productivity of land is reflected in the Indonesian saying: 'without bamboo, the land dies'. Bamboo plays a key role in restoring soil fertility through the accumulation of organic matter and nutrients during the fallow period. The slow decomposition of bamboo litter produces a thick organic layer which conserves moisture and minimises surface runoff and erosion in addition to its nutritional contributions.

Because of the increasing population and economic pressure, farmers are shortening the fallow period and intensifying the cropping. Consequently, there is a decline in soil organic matter accumulation, which is often associated with a decline in soil fertility. This reduction in soil organic matter accumulation can theoretically be compensated for by higher fertiliser input to the system. However, few farmers can afford to buy the extra fertiliser and this leads to declining production over successive years (Christanty, 1989). The condition becomes even worse when short fallow period talun-kebum is practiced on nutrient poor or dry sites.

External market demand and higher prices for cash crops provide a motivation for farmers to switch from bamboo to more economically valuable crops such as cloves and mandarines. However, while the gross income may be higher, these two crops require high fertiliser inputs, as well as intensive pest and disease control, which often involves the use of pesticides. As a result, farmers face higher production costs and higher risks, particularly if the more intensive input requirements are not met (Christanty et al., 1986).

Increasing organic production is undoubtedly a worthwhile objective; however, one should remember that production is not the only function of the bamboo talun-kebum. Indonesian farmers have structured their cropping pattern in a way that fulfills various needs: food production, efficient distribution of labour, pest control, nutrient cycling, firewood and building materials, and the flexibility to deal with environmental and social fluctuations (Marten, 1986). Since most farmers gain their farming knowledge from both local tradition and trial and error, adequate extension education and training on basic land management should be provided before or accompanying any attempt to improve their agricultural systems or to introduce new species.

The challenge for development in the mountainous areas of West Java is to improve bamboo talun-kebum in a way that retains the benefits of its traditional practice while meeting the changing needs of the farmers. Since all components of the system are interconnected, the strategy for improvement should be based on a holistic approach, striking a balance between productivity and sustainability.

## References

- Bene, J.G., Beall, H.W. and Côté, A., 1977. Trees, food and people: land management in the tropics. IDRC-084e, International Development Research Centre, Ottawa, 52 pp.
- Christanty, L., 1989. Analysis of the sustainability and management of the *talun-kebun* system of West Java, Indonesia. Ph.D. Thesis, University of British Columbia, Canada, 276 pp.
- Christanty, L., Abdoellah, O.S., Marten, G.G. and Iskandar, J., 1986. Traditional agroforestry in West Java: the pekarangan (homegarden) and *kebun-talun* (annual-perennial rotation) cropping systems. In: G.G. Marten (Editor), *Traditional Agriculture in Southeast Asia: A Human Ecology Perspective*. Westview Press, Boulder, CO, pp. 132–158.
- Grandstaff, T.B., 1980. Shifting cultivation in Northern Thailand: possibility for development. *Resource Systems Theory and Methodology Series 3, NRTS-11/UNUP-192*, United Nations University, Tokyo, 44 pp.
- Jordan, C.F., 1985. *Nutrient Cycling in Tropical Forest Ecosystem—Principles and their Application in Management and Conservation*. Wiley, Chichester.
- Kimmins, J.P., 1995. The health and integrity of forest ecosystems. Are they threatened by forestry? *Proc. of the 1994 SAF/CIF Convention*, Anchorage, AL, 18–22 September, Society of American Foresters, Bethesda, MD, pp. 22–40.
- Marten, G.G., 1986. Traditional agriculture and agricultural research. In: G.G. Marten (Editor), *Traditional Agriculture in Southeast Asia: A Human Ecology Perspective*. Westview Press, Boulder, CO, pp. 326–340.
- Nair, P.K.R., 1993. *An Introduction to Agroforestry*. Kluwer, Dordrecht, 496 pp.
- Norman, M.J.T., 1979. *Annual Cropping Systems in the Tropics—An Introduction*. University Press of Florida, Gainesville.
- Palte, J.G.L., 1988. Upland mixed-garden agroforestry on Java, Indonesia. *Neth. Rev. Dev. Stud.*, 1988(1989): 81–93.
- Sanchez, P.A., 1976. *Properties and Management of Soils in the Tropics*. Wiley, New York.
- Satjapradja, O., 1982. Agroforestry—a promising system for optimizing and diversifying the forest resource. In: P.B.L. Srivastava et al. (Editors), *Tropical Forests—Source of Energy through Optimization and Diversification*. University of Pertanian Malaysia, Serdang, pp. 147–150.
- Soemarwoto, O., Christanty, L., Henky, Herri, Y.H., Iskandar, J., Hadyana and Priyono, 1985. The *talun-kebun*: a man-made forest fitted to family needs. *Food Nutr. Bull.*, 7(3): 48–51.
- Stark, N. and Jordan, C.F., 1978. Nutrient retention by the root mat of an Amazonian rainforest. *Ecology*, 59: 434–437.